

# AFTERSALES TRAINING – W16 MOTOR. ANSAUGSYSTEM.

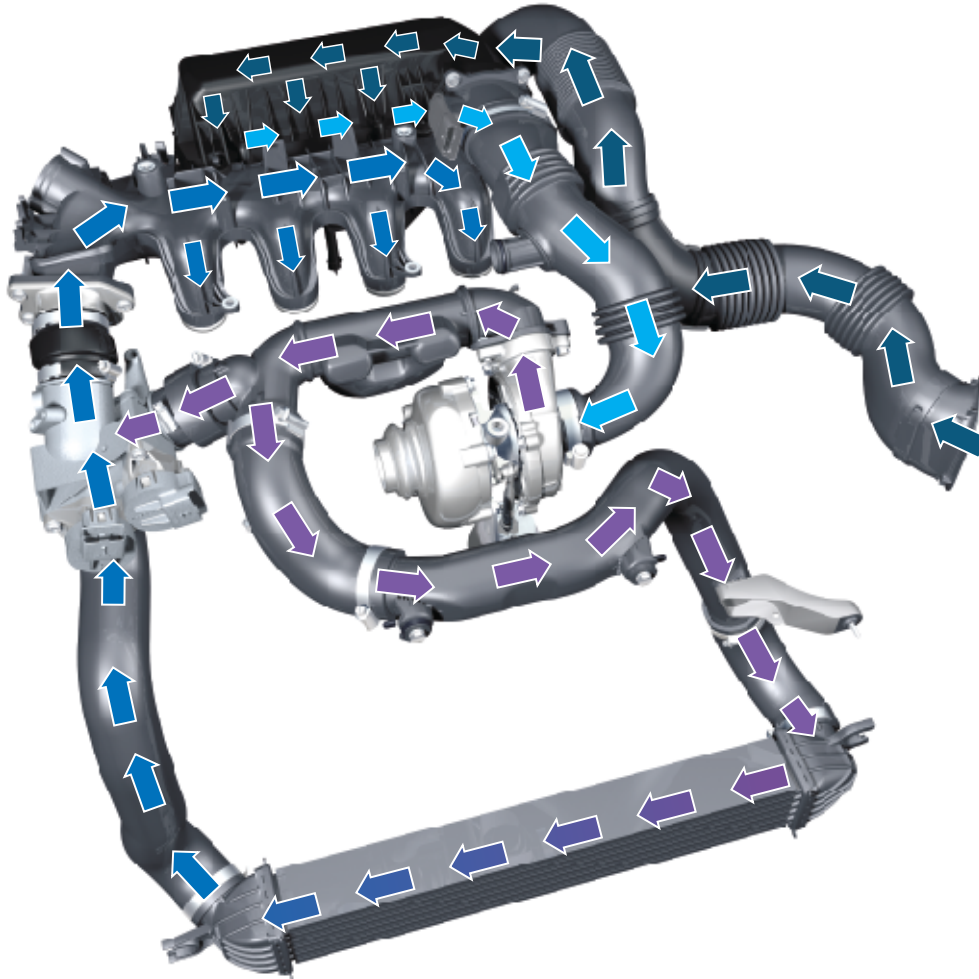

**MINI SERVICE**

# AFTERSALES TRAINING – W16 MOTOR. KRAFTSTOFFSYSTEM.

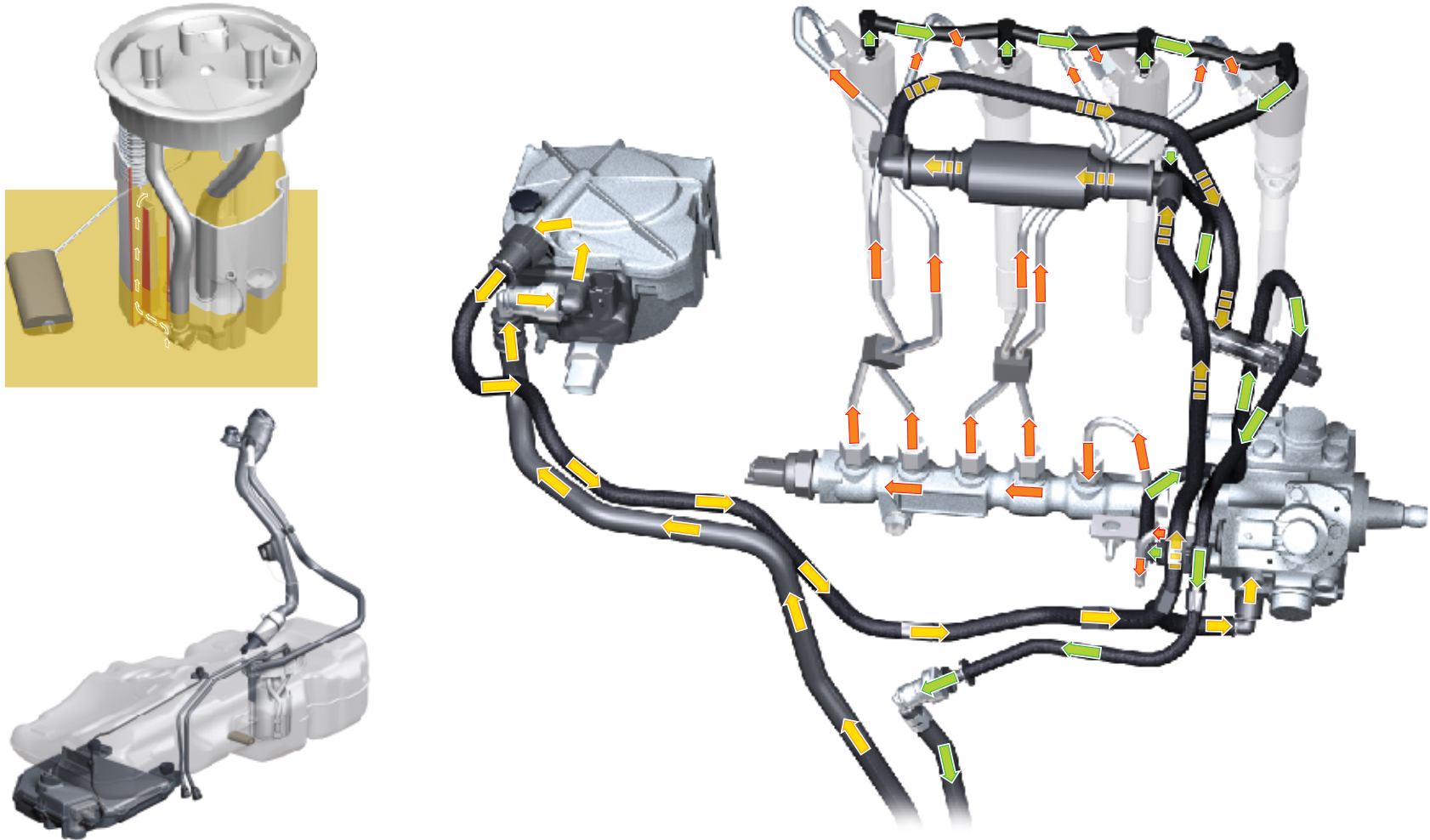

**MINI SERVICE**

# AFTERSALES TRAINING – W16 MOTOR. KRAFTSTOFFVERSORGUNG.

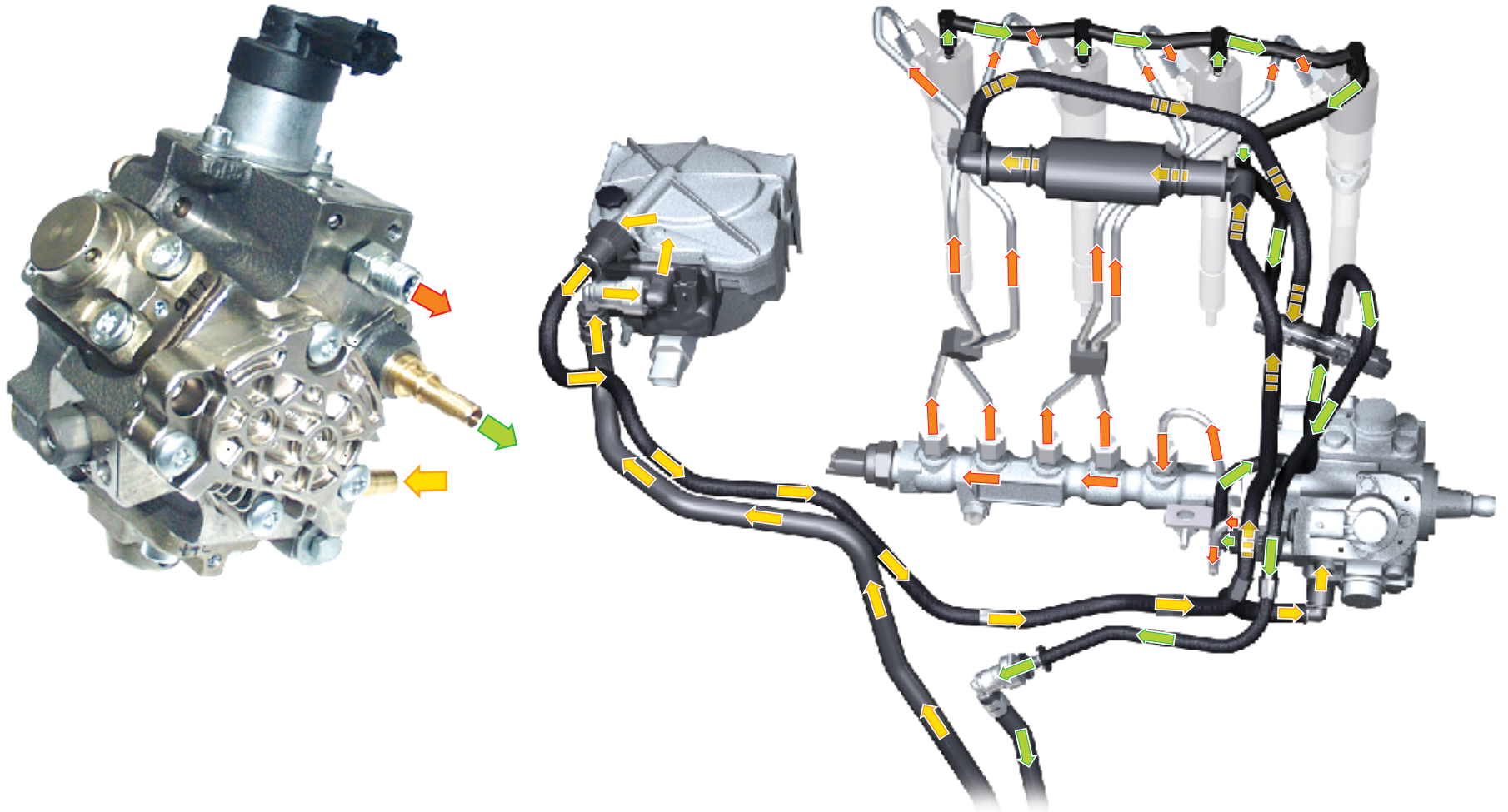

**MINI SERVICE**

# AFTERSALES TRAINING – W16 MOTOR. KÜHLKREISLAUF.

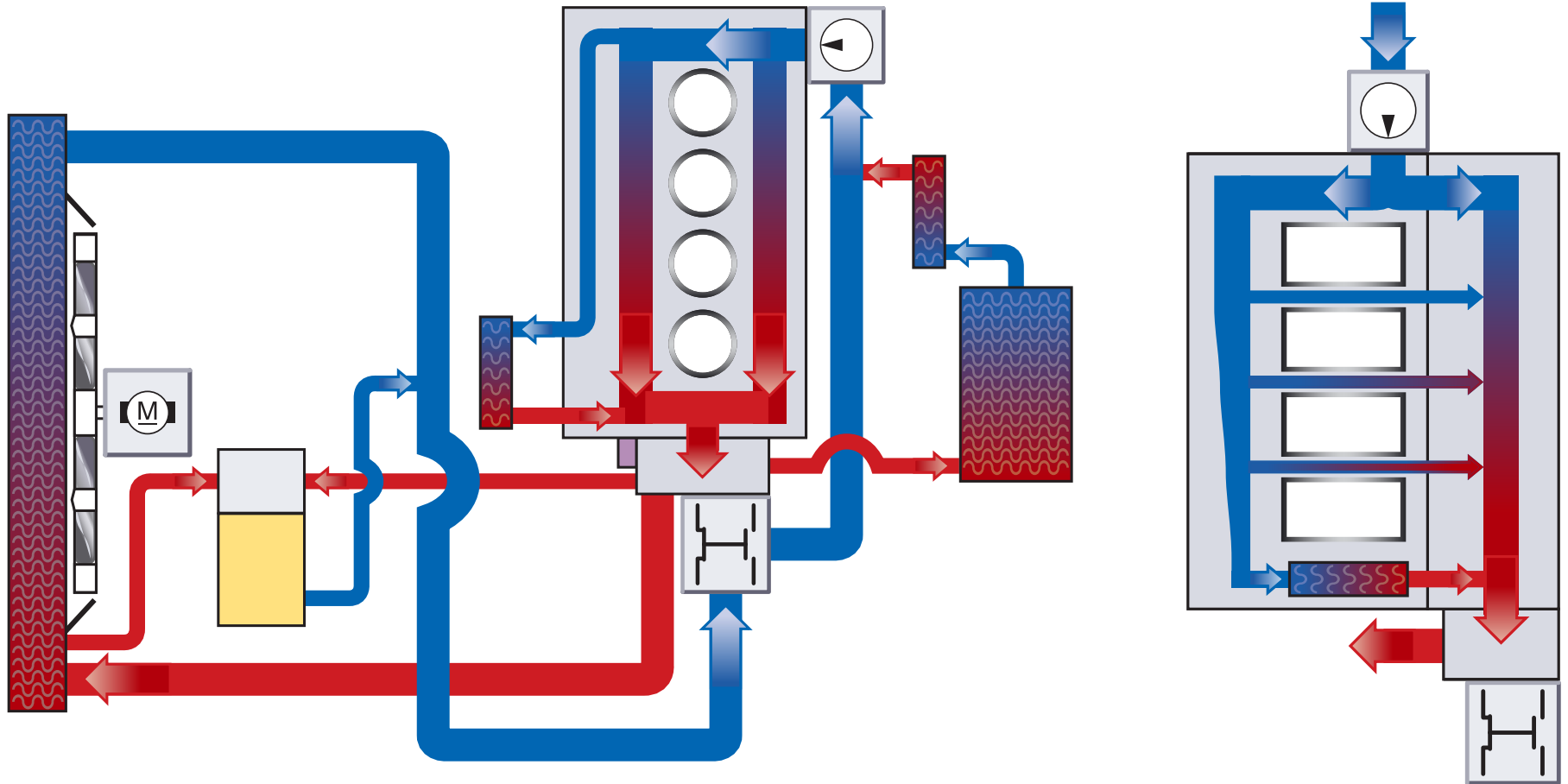

MINI SERVICE

# AFTERSALES TRAINING – W16 MOTOR. TECHNISCHE DATEN.

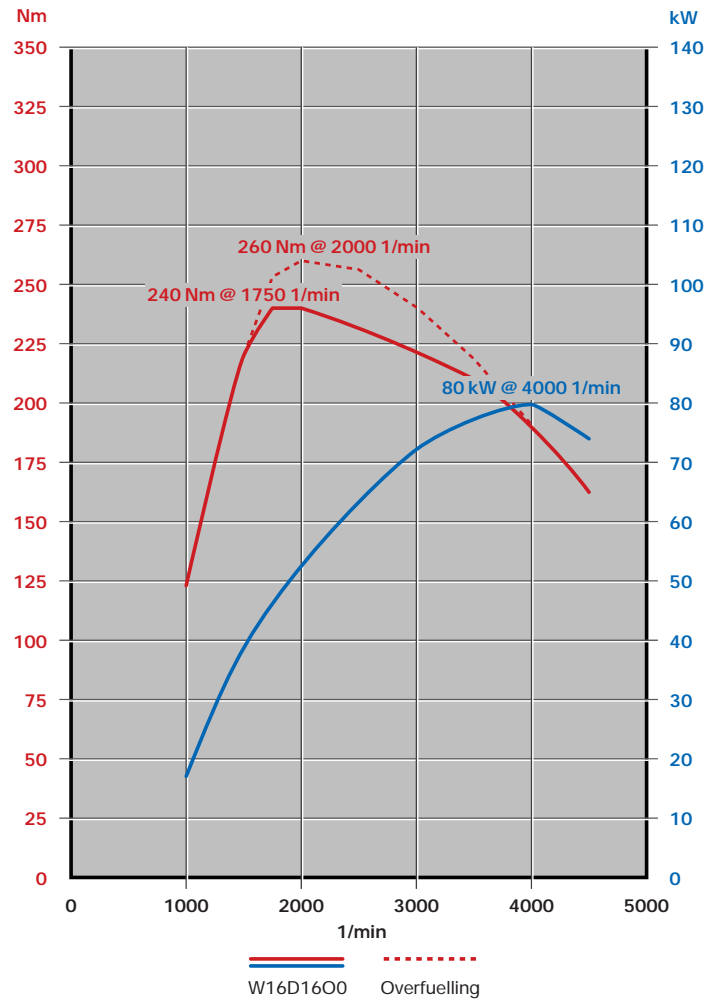

**MINI SERVICE**

# AFTERSALES TRAINING – W16 MOTOR. VORGLÜHZEITEN.

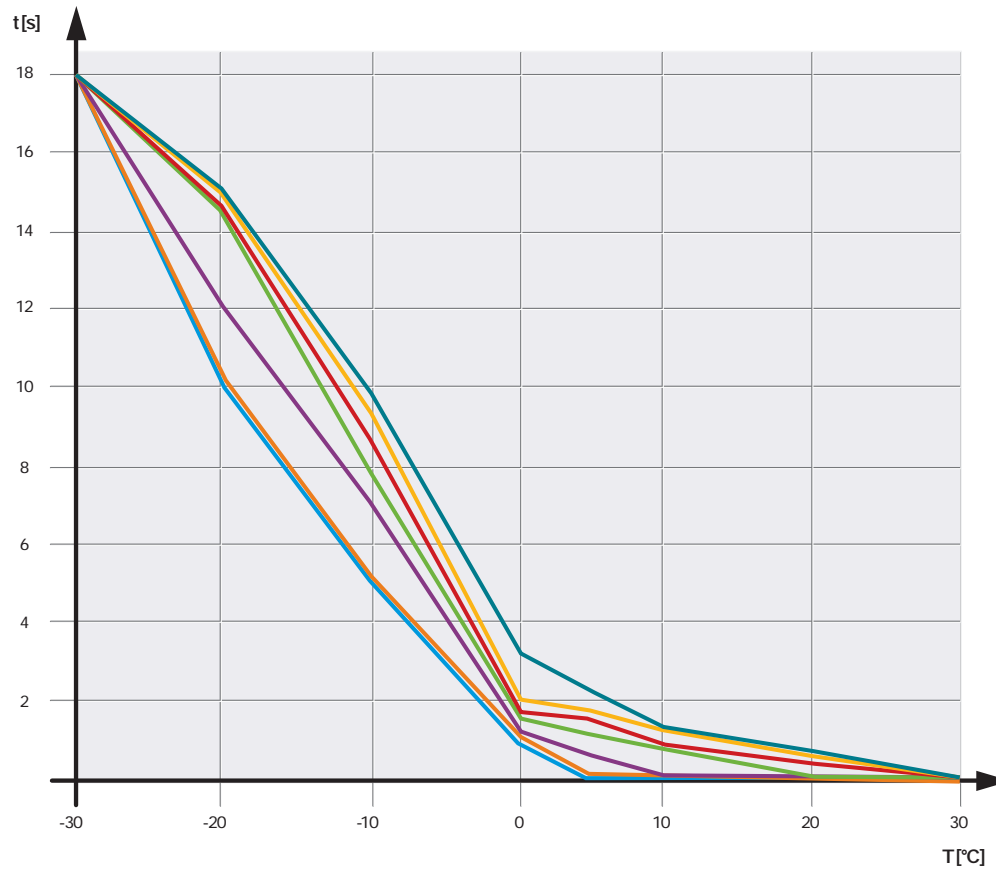

- 1 Kennlinie bei 700 mbar Luftdruck
- 2 Kennlinie bei 750 mbar Luftdruck
- 3 Kennlinie bei 800 mbar Luftdruck
- 4 Kennlinie bei 850 mbar Luftdruck
- 5 Kennlinie bei 900 mbar Luftdruck
- 6 Kennlinie bei 950 mbar Luftdruck
- 7 Kennlinie bei 1000 mbar Luftdruck



**MINI SERVICE**